

*3.8m Commercial Antenna
Az-EI Mount*

PATRIOT

LIMITED TWELVE (12) MONTH WARRANTY

This PATRIOT ANTENNA equipment is warranted to be free from defects in material and workmanship under normal use and service. PATRIOT ANTENNA shall repair or replace defective equipment, at no charge, or at its option, refund the purchase price, if the equipment is returned to PATRIOT ANTENNA not more than twelve (12) months after shipment. Removal or reinstallation of equipment and its transportation shall not be at cost of PATRIOT ANTENNA except PATRIOT ANTENNA shall return repaired or replaced equipment freight prepaid.

This Warranty shall not apply to equipment which has been repaired or altered in any way so as to affect its stability or durability, or which has been subject to misuse, negligence or accident. This Warranty does not cover equipment which has been impaired by severe weather conditions such as excessive wind, ice, storms, lightning, or other natural occurrences over which PATRIOT ANTENNA has no control, and this Warranty shall not apply to equipment which has been operated or installed other than in accordance with the instructions furnished by PATRIOT ANTENNA.

Claimants under this Warranty shall present their claims along with the defective equipment to PATRIOT ANTENNA immediately upon failure. Noncompliance with any part of this claim procedure may invalidate this warranty in whole or in part.

THIS WARRANTY IS EXPRESSLY IN LIEU OF ALL OTHER AGREEMENTS AND WARRANTIES, ANY IMPLIED WARRANTY OF MERCHANTABILITY OR FITNESS FOR A PARTICULAR PURPOSE IS LIMITED IN DURATION TO THE DURATION OF THIS WARRANTY. PATRIOT ANTENNA DOES NOT AUTHORIZE ANY PERSON TO ASSUME FOR IT THE OBLIGATIONS CONTAINED IN THIS WARRANTY AND PATRIOT ANTENNA NEITHER ASSUMES NOR AUTHORIZES ANY REPRESENTATIVE OR OTHER PERSON TO ASSUME FOR IT ANY OTHER LIABILITY IN CONNECTION WITH THE EQUIPMENT DELIVERED OR PROVIDED.

IN NO EVENT SHALL PATRIOT ANTENNA BE LIABLE FOR ANY LOSS OF PROFITS, LOSS OF USE, INTERRUPTION OF BUSINESS, OR INDIRECT, SPECIAL OR CONSEQUENTIAL DAMAGES OF ANY KIND.

In no event shall PATRIOT ANTENNA be liable for damages in an amount greater than the purchase price of the equipment.

Some states do not allow limitations on how long an implied warranty lasts, or allow the exclusion or limitation of incidental or consequential damages, so the above limitations or exclusions may not apply to you.

PATRIOT ANTENNA has the right to void the warranty when the antenna is installed by someone other than a certified installer.

Product Serial Number- _____

Date Purchased- _____

Patriot Antenna Systems

704 North Clark Street

Albion, MI 49224 USA

Tel: (517)629-5990

Fax: (517)629-6690

E-mail: info@sepatriot.com

IMPORTANT!!!

INSTALLATION OF THIS PRODUCT SHOULD BE PERFORMED ONLY BY A PROFESSIONAL INSTALLER AND IS NOT RECOMMENDED FOR CONSUMER D.I.Y. (DO-IT-YOURSELF) INSTALLATIONS.

WATCH FOR WIRES!

Installation of this product near power lines is dangerous. For your own safety, follow these important safety rules.

1. Perform as many functions as possible on the ground.
2. Watch out for overhead power lines. Check the distance to the power lines before starting installation. We recommend you stay a minimum of 6 meters (20 feet) from all power lines.
3. Do not use metal ladders.
4. Do not install antenna or mast assembly on a windy day.
5. If you start to drop antenna or mast assembly, get away from it and let it fall.
6. If any part of the antenna or mast assembly comes in contact with a power line, call your local power company. DO NOT TRY TO REMOVE IT YOURSELF! They will remove it safely.
7. Make sure that the mast assembly is properly grounded.

WARNING

Assembling dish antennas on windy days can be dangerous. Because of the antenna surface, even slight winds create strong forces. For example, a 1.0m antenna facing a wind of 32 km/h (20 mph) can undergo forces of 269 N (60 lbs.). Be prepared to safely handle these forces at unexpected moments. Do not attempt to assemble, move or mount dish on windy days or serious, even fatal accidents may occur. PATRIOT ANTENNA SYSTEMS is not responsible or liable for damage or injury resulting from antenna installations.

WARNING

Antennas improperly installed or installed to an inadequate structure are very susceptible to wind damage. This damage can be very serious or even life threatening. The owner and installer assumes full responsibility that the installation is structurally sound to support all loads (weight, wind & ice) and properly sealed against leaks. PATRIOT ANTENNA SYSTEMS will not accept liability for any damage caused by a satellite system due to the many unknown variable applications.

Introduction

Thank you for purchasing your Patriot Commercial Antenna. We trust that you will find this to be a well designed product that will provide many years of reliable service. Please read this manual thoroughly before beginning assembly. For best results in the assembly process, perform each step in the same sequence as listed in this manual. Record the serial number of the unit on to page two for future reference and read the warranty information. The serial number plate can be found on the hub.

Unpacking and Inspection

Shipping cartons should be unpacked and contents checked for damaged or missing parts. Should there be any parts that are damaged or missing, please contact technical support for replacement.

Site Selection

The main objective of conducting a site survey utilizing a compass and inclinometer is to choose a mounting location on the ground that will give you the greatest amount of swing for azimuth and elevation for present as well as future use. A thorough pre-installation site survey is strongly recommended because it can alert you to any "look angle", soil, wind or other problems.

The first and most important consideration when choosing a prospective antenna site is whether or not the area can provide an acceptable "look angle" to the satellite. A site with a clear, unobstructed view facing south, southeast is required. Your antenna site must be selected in advance so that you will be able to receive the strongest signal available. Also consider obstructions that may occur in the future such as the growth of trees.

It is important to conduct an on-site survey with a portable antenna or with a compass and clinometer to avoid interference, obstructions, etc.

When selecting "look angle", be sure to observe and take readings approximately 10 deg to the left and right, above and below your selected "look angle".

Before Ground Pole Installation, the soil type should be checked because soil conditions vary widely in composition and load bearing capacity. A soil check will help you to determine the type and size of foundation required to provide a stable base for the antenna.

Before digging is done, information regarding the possibility of underground telephone lines, power lines, storm drains, etc., in the excavation area should be obtained from the appropriate agency.

As with any other type of construction, a local building permit may be required before installing an antenna. It is the property owner's responsibility to obtain any and all permits. Ground mounts are certified for 125 mph wind survival.

ITEM #	PART#	DESCRIPTION	QTY	REV
1	231104G	BLOCK, 3.1 PIVOT GALV	1	000
2	231106	PLATE, C-BAND 3.1/3.8/405	1	000
3	238011	ASSY, 3.8AzEI MOUNT	1	002
(See Page 7 for further break down on this item)				
4	238002	ASSY, 3.8 THREADED ROD	1	001
5	238004	ASSY, 3.8 COMMON HUB	1	000
6	238005	OUT BRD SKIRT, 3.8 PRIME	16	000
7	238006	RADIAL BEAM 3.8 PRIME	16	000
8	238007W	PETAL, 3.8 PRIME	16	000
9	238009	STRUT, 3.8 PRIME STRD FD	4	000
10	238020	BRACE, 3.8 BACK SUPPORT	1	000
11	238108	PLATE, CENTER 3.8	1	000
12	4M38009	ANGLE,3.8 PRIME FEED STRUT ANGLE	4	000
PG 8	4M38004	ANGLE,3.8 HUB	16	000

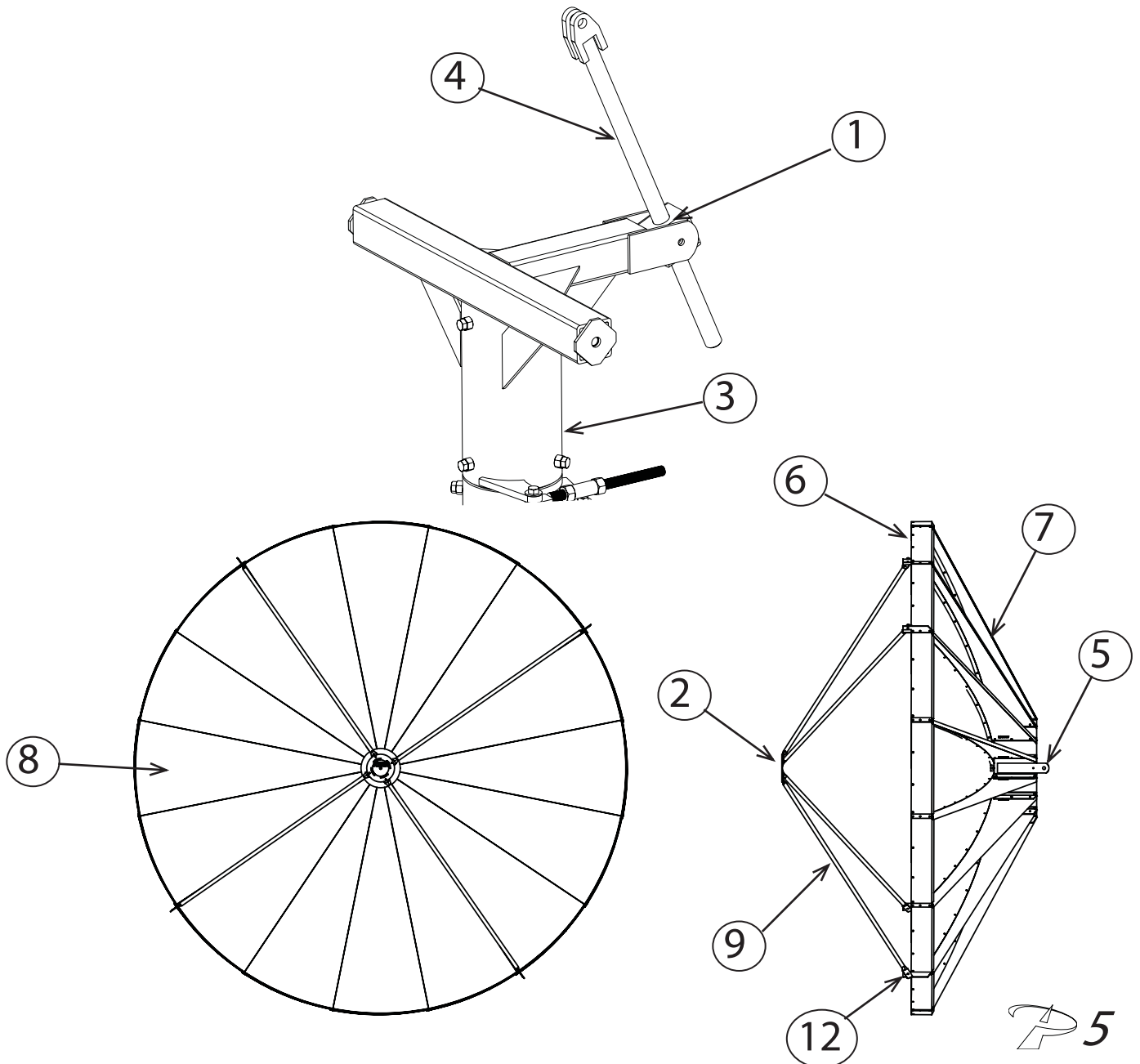

8 7 6 5 4 3 2 1

ITEM NO.	PART NUMBER	Default/Qty.
1	20000021	4
2	4BPTBK38455	1
3	3HTG0002	4
4	3HNG0001	16
5	3HWG0001	8
	PRT-BTKPS	

DISCARD TEMPLATE BEFORE SETTING MOUNT

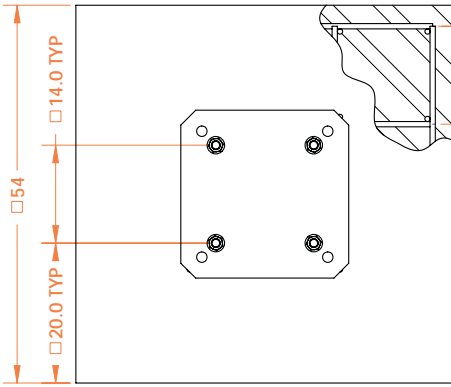
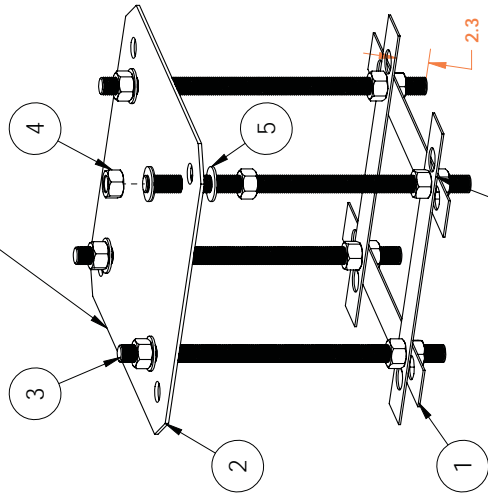

3.0 TYP
14.00 ON CENTER TYP

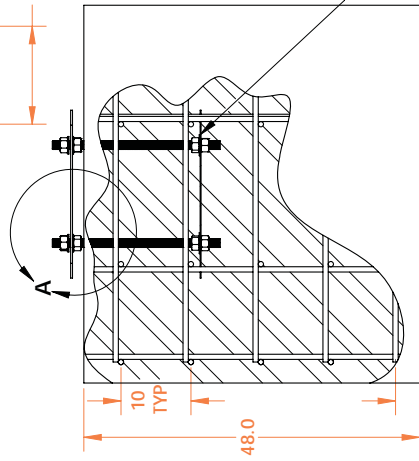

KEEP FOUNDATION PLATES UNDER REBAR

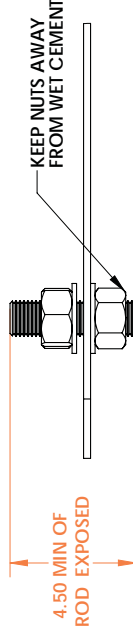

KEEP NUTS AWAY FROM WET CEMENT

NOTES:

1. SOIL BEARING CAPACITY = 2000 PSF
2. CONCRETE, 3000 PSI AT 28 DAYS, POURED & VIBRATED AGAINST UNDISTURBED SOIL. ALLOW (24) HOURS FOR CONCRETE TO SET BEFORE INSTALLATION OF ANTENNA. ESTIMATED CONCRETE USAGE = 3.0 YARDS
3. USE #4 (Ø1/2) RE-BAR IN CONCRETE PAD. ESTIMATED USAGE = 160 FT.
4. ANCHOR RODS, WASHERS, AND NUTS SHALL BE GRADE 5 OR BETTER, GALVANIZED. (HW&E & TEMPLATE KIT IS AVAILABLE FROM PATRIOT ANTENNA SYSTEMS PART # PRT-BTKPS).
5. WHEN THE FROST LINE IS BELOW (10) INCHES THE BASE SLAB/SOIL REQUIRES SPECIAL DESIGN CONSIDERATIONS TO PREVENT HEAVING; CONSULT A LOCAL LICENSED CIVIL ENGINEER.
6. LIGHTNING AND GROUNDING PROVISIONS PER LOCAL REGULATIONS.

PATRIOT 704 North Clark Street, Addison, IL 60204 USA

NAME	DATE
DRAWN BY: Dan Pratt	05/19/2008
ENG APPR: D PRATT	05/19/2008

FOUNDATION, 3.8m PRIME FOCUS W/ OPTIONAL PIPE STAND MOUNT

NOTES:

UNLESS OTHERWISE SPECIFIED: DIMENSIONS ARE IN INCHES; CORNERS ARE AT 70°

PROPRIETARY AND CONFIDENTIAL
THE INFORMATION CONTAINED IN THIS DRAWING IS THE SOLE PROPERTY OF PATRIOT ANTENNA SYSTEMS. NO REPRODUCTION IN PART OR AS A WHOLE WITHOUT THE WRITTEN PERMISSION OF PATRIOT ANTENNA SYSTEMS IS PROHIBITED.

TOLERANCES:
FRACTIONAL 1/8"
DECIMAL .005"
X ± .005"
XX ± .020"
XXX ± .065"

SIZE DWG. NO.

B 2FD380P0001

REV

000

SCALE: 1:32

SHEET 1 OF 1

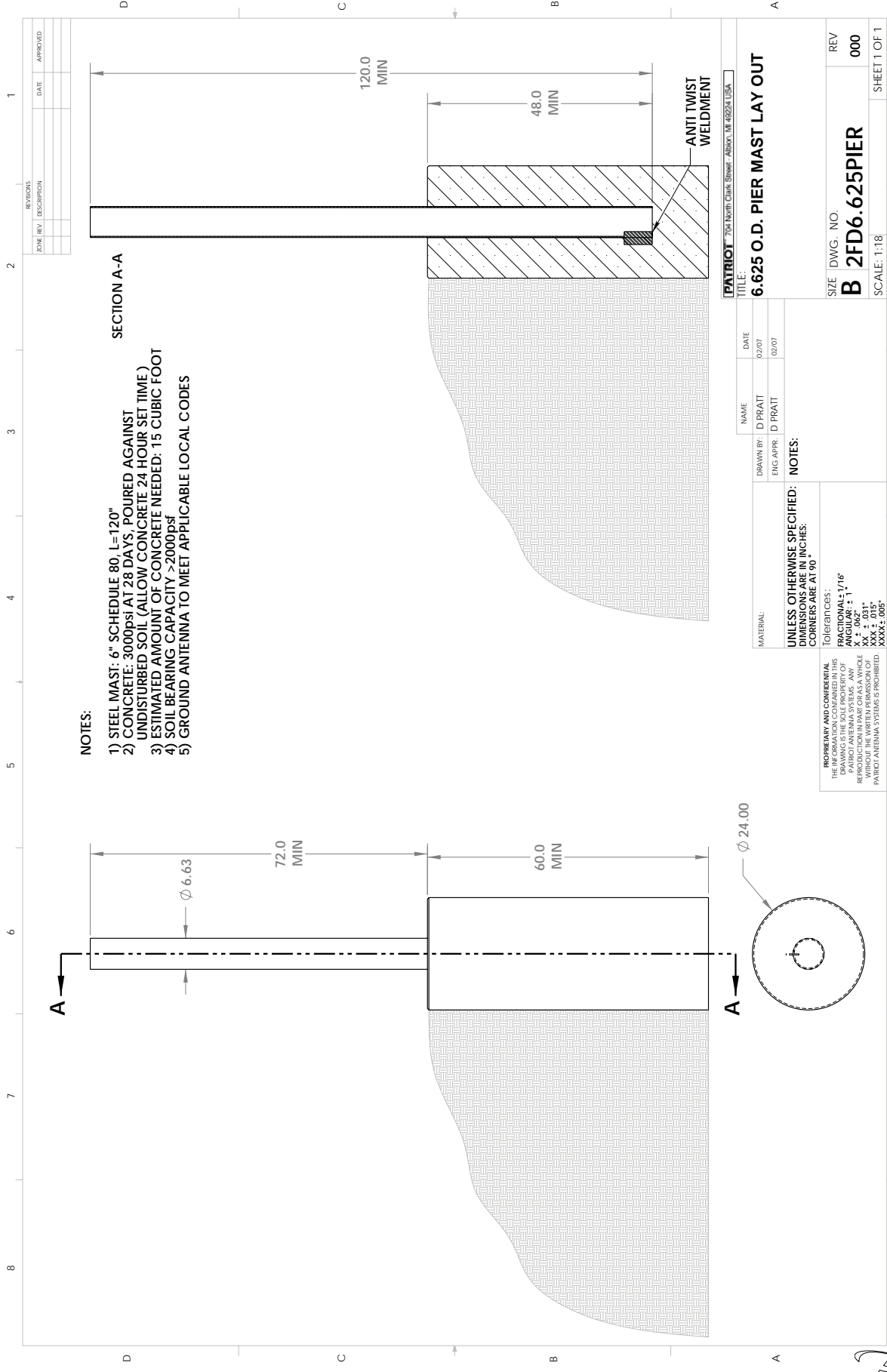

NOTES:

- 1) STEEL MAST: 6" SCHEDULE 80, L=120"
- 2) CONCRETE: 3000psi AT 28 DAYS, POURED AGAINST UNDISTURBED SOIL (ALLOW CONCRETE 24 HOUR SET TIME)
- 3) ESTIMATED AMOUNT OF CONCRETE NEEDED: 15 CUBIC FOOT
- 4) SOIL BEARING CAPACITY >2000psf
- 5) GROUND ANTENNA TO MEET APPLICABLE LOCAL CODES

SECTION A-A

REV	DATE	DESCRIPTION	APPROVED

TITLES: PATRIOT™ 704 North Clark Street, Alton, IL 62921, USA 6.625 O.D. PIER MAST LAY OUT		REV 000
SIZE 1/8"	DWG. NO. B 2FD6.625PIER	SCALE 1:18
MATERIAL: UNLESS OTHERWISE SPECIFIED: DIMENSIONS ARE IN INCHES; CORNERS ARE AT 90° TOLERANCES: FRACTIONAL: 1/16" DECIMAL: .015" ANGLES: .031" HOLE DIA: .005" HOLE DIA: .005"	NAME D PRATT	DATE 02/07
PROBES AND CONDUITS: THE INFORMATION CONTAINED IN THIS DRAWING IS THE SOLE PROPERTY OF PATRIOT ANTENNA SYSTEMS. ANY REPRODUCTION OR TRANSMISSION OF THIS DRAWING WITHOUT THE WRITTEN PERMISSION OF PATRIOT ANTENNA SYSTEMS IS PROHIBITED.	DRAWN BY: D PRATT	ENG. APPR.: D PRATT

Fine Tune Assembly

1. Slide pre-assembled fine tune mount assembly over post.
2. Point mount towards general location of desired satellite.
3. Draw bolts on Prt# 238014 tight to pipe.
4. Snug bolts on Prt# 238018 to pipe. (Do not tighten at this time. Make contact to hold mount in place during hub install)

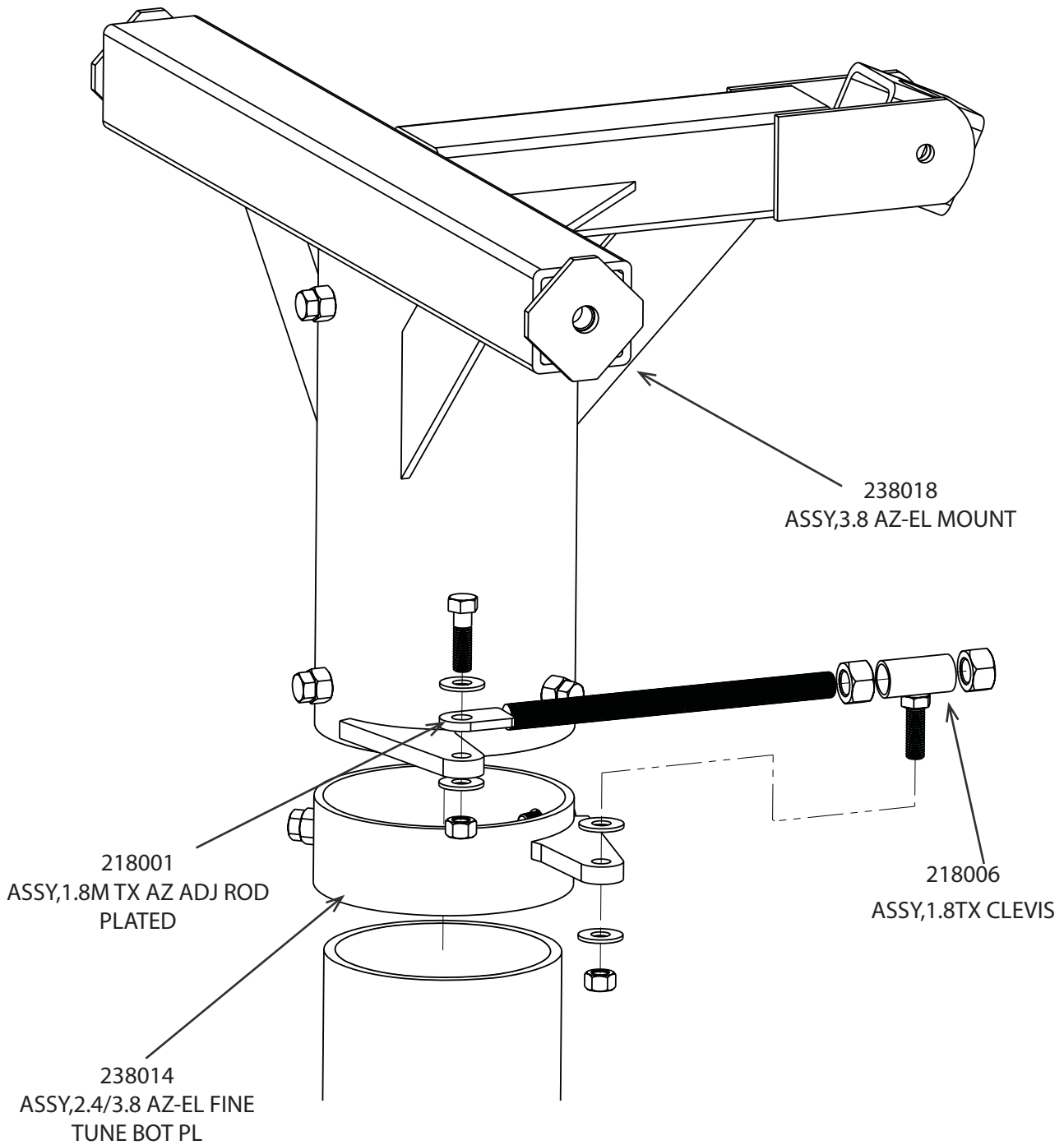

Mount Assembly

1. Place the pre-assembled Az-EI pole mount on top of the 6 5/8" OD pipe, leaving the bolts loose. (As stated on previous page)
2. Add nuts and washers from the **Az-EI Elevation** pack hardware to the Threaded Elevation Rod as shown. Thread the nut all the way up to the welded end. Insert the rod into the Anchor Block pre-assembled on the Az-EI pole mount.
3. With 2 helpers place the hub assembly in the zenith (bird bath) position on top of the Az-EI mount as shown. Insert bolts and washers to hold the hub assembly to the mount cross bar. Assemble the Threaded Elevation Rod to the hub extension as shown using pre-installed 1/2" hardware.

NOTE: You must position the hub in the position shown below or it will be unsafe to build the reflector. You will also be able to assemble the dish with out moving your ladder. With the mount pipe bolts loose the dish can spin on the pipe for ease of assembly.

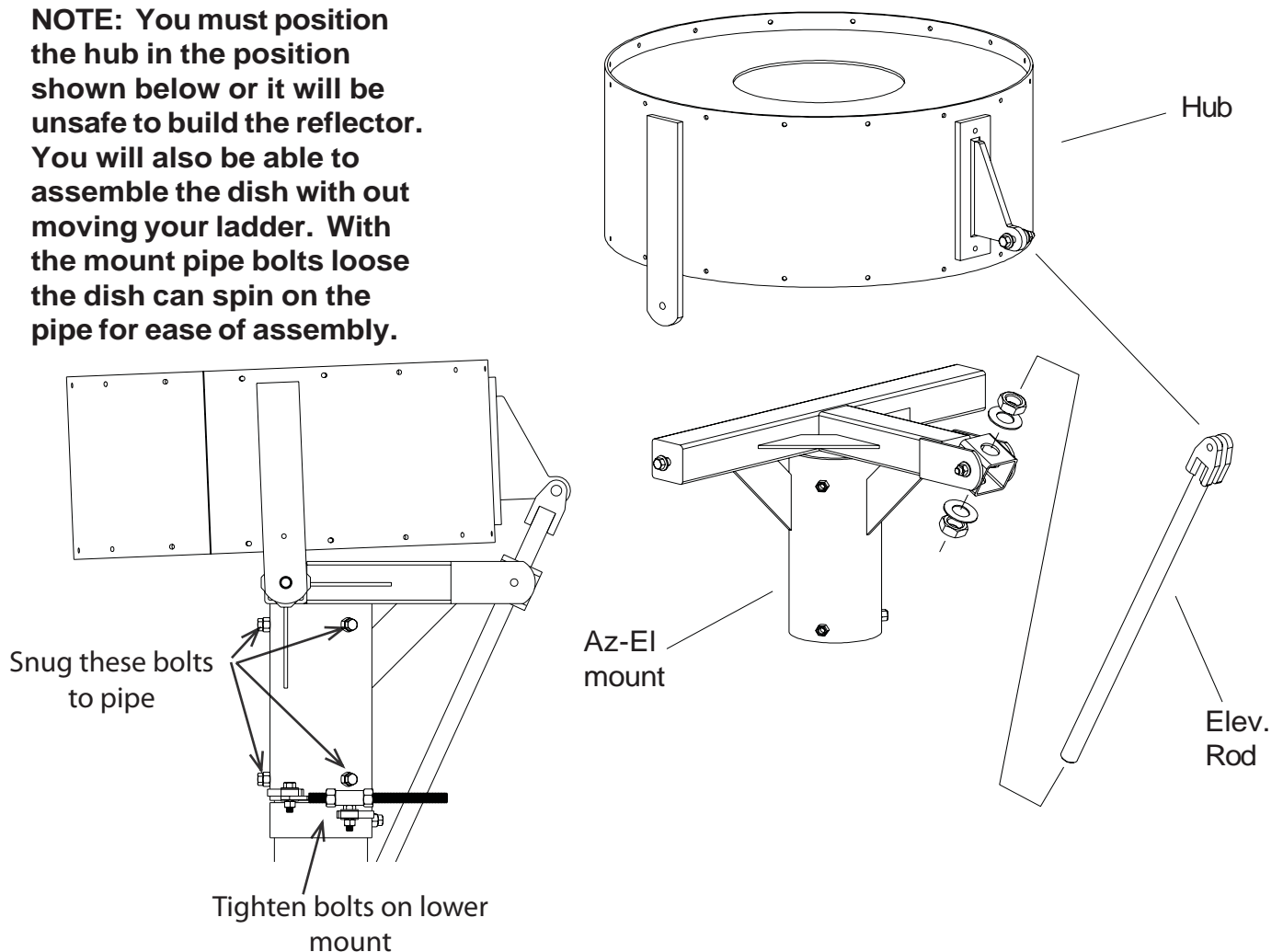

Reflector Assembly

4. Install the Hub Angles to the Hub assembly using hardware labeled- **Hub Angle to Hub**, placing the angle cut leg toward the ground as shown. Use 2 bolts, 4 washers, and 2 nuts per.

5. Install the Radial Beams to the Hub Angles using hardware labeled- **Radial Beam to Hub**. Use 3 bolts, 6 washers, and 3 nuts per. Tighten this hardware as it is installed.

NOTE: Be sure to place the Radial Beam on the outside of the Hub angle as shown.

6. Now install all of the Outboard Skirts on the end of the Radial Beams (bent edge down) using hardware labeled **Outboard Skirt**. Leave this hardware loose.

NOTE: One end has a formed "overlap". Place this end on the outside.

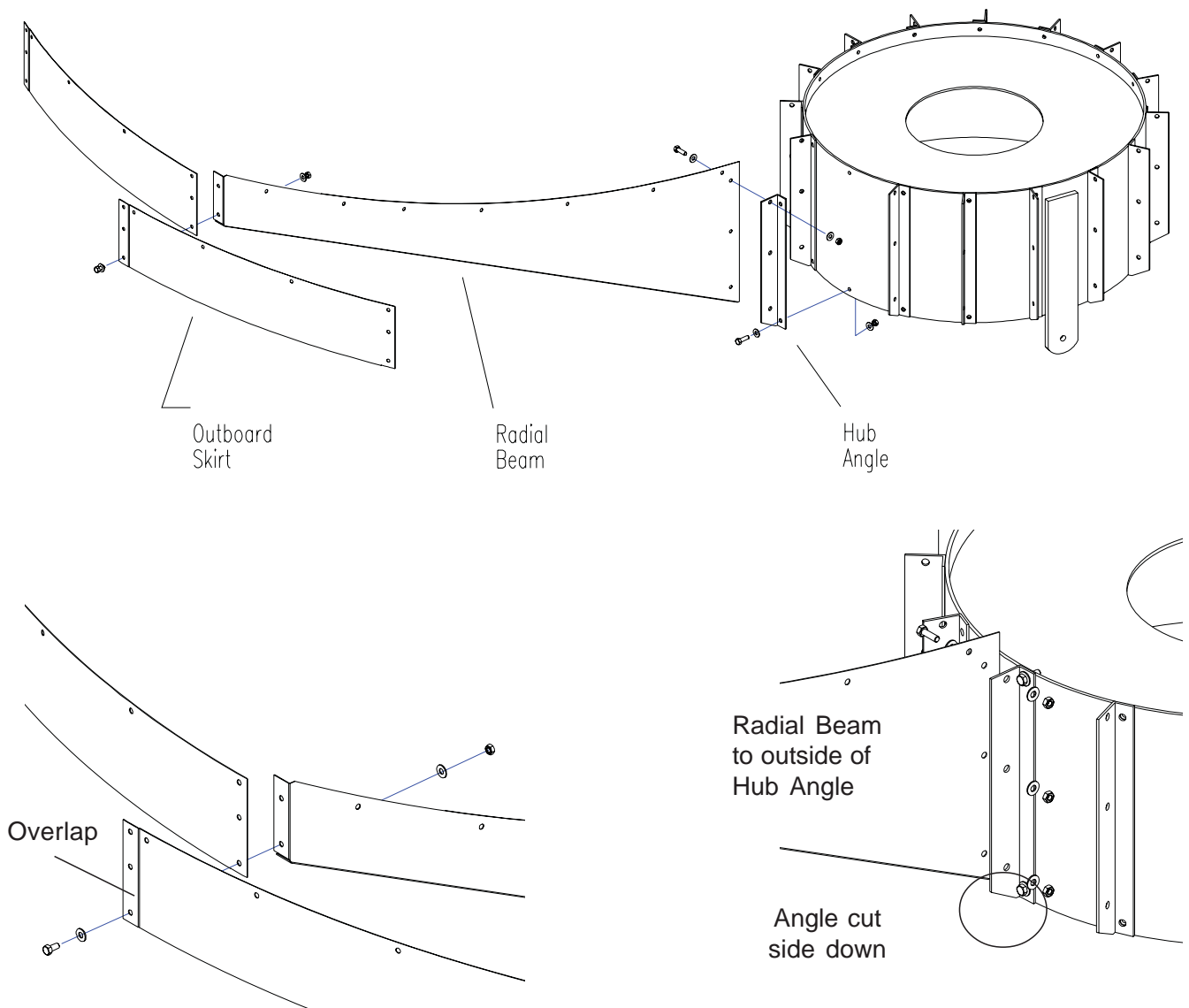

7. Set in place 2 Petals between the Radial Beams. The Radial Beam will be between the flange of each Petal. Using 3 tapered alignment tools- 2 in the outermost holes, and 1 in the center hole to align the holes in the panels and radial beam, install the hardware in the remaining holes from kit labeled- **Petal to Radial Beam**. Use 1 bolt, 2 washers, and 1 nut per hole. Pull the tapered alignment tools and install that hardware. Leave hardware loose at this time. Continue installing the remaining Petals using this method.

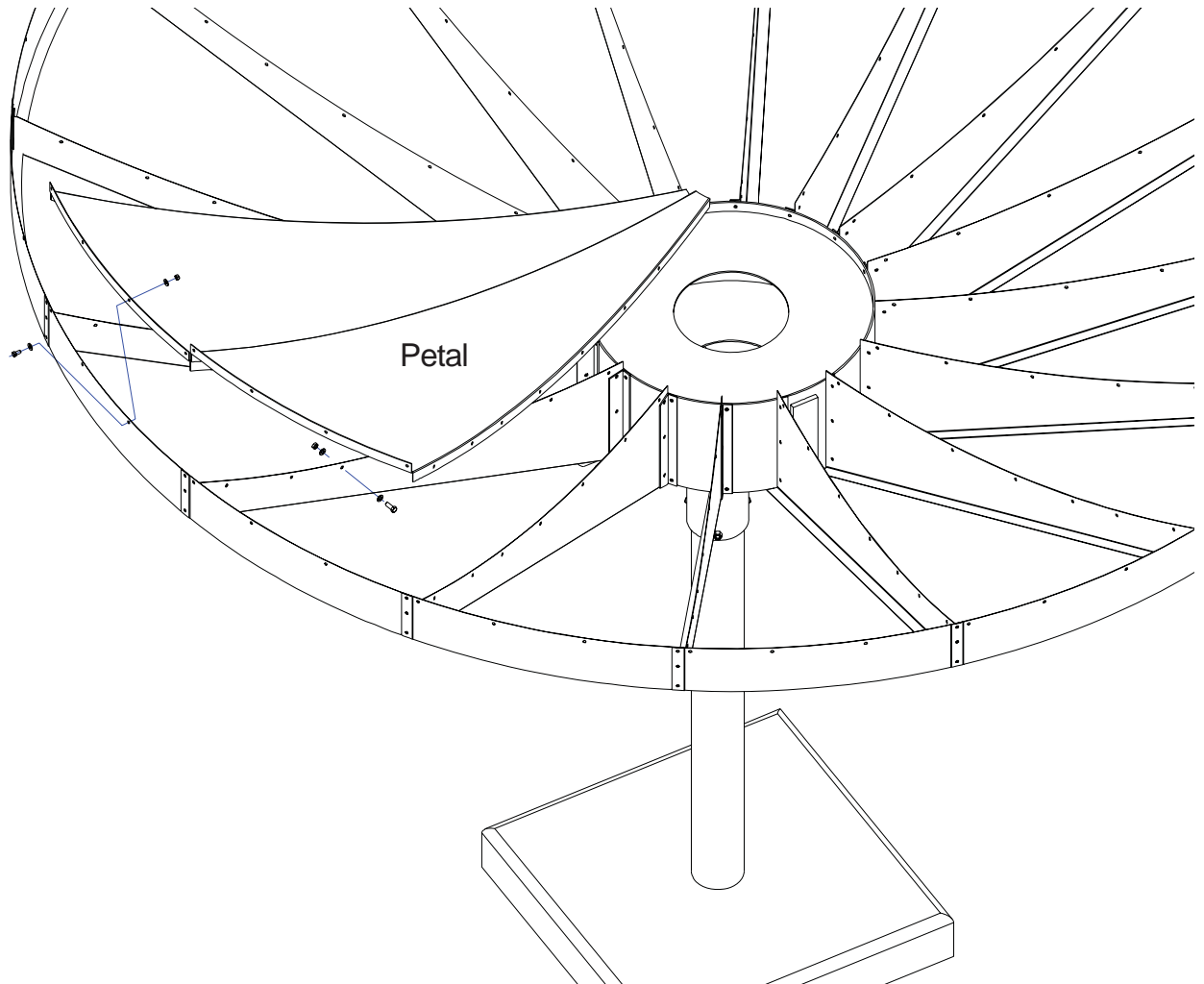

Tightening Procedure- Important!

8. Starting at the Hub tighten all hardware by working outward 1 circular row at a time.
9. When all petals are tight put in the remaining hardware from the **Outboard Skirt** pack. At every 4th Radial Beam/Outboard Skirt junction include an Outboard Feed Angle as you assemble using hardware kit labeled- **Feed Strut Bottom**. Tighten hardware as you install it.

Reflector and Feed Support Assembly

10. Place the Feed Struts in place with the straight end assembled to the Outboard Feed Angles at the edge of the dish. Use **Feed Strut Top** pack hardware.

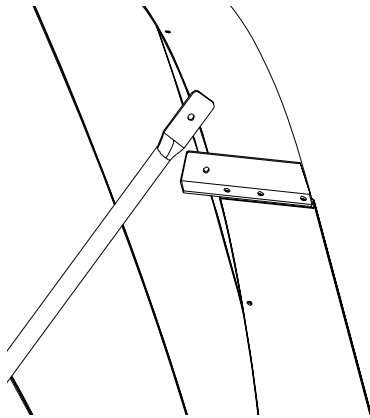

Feed Struts

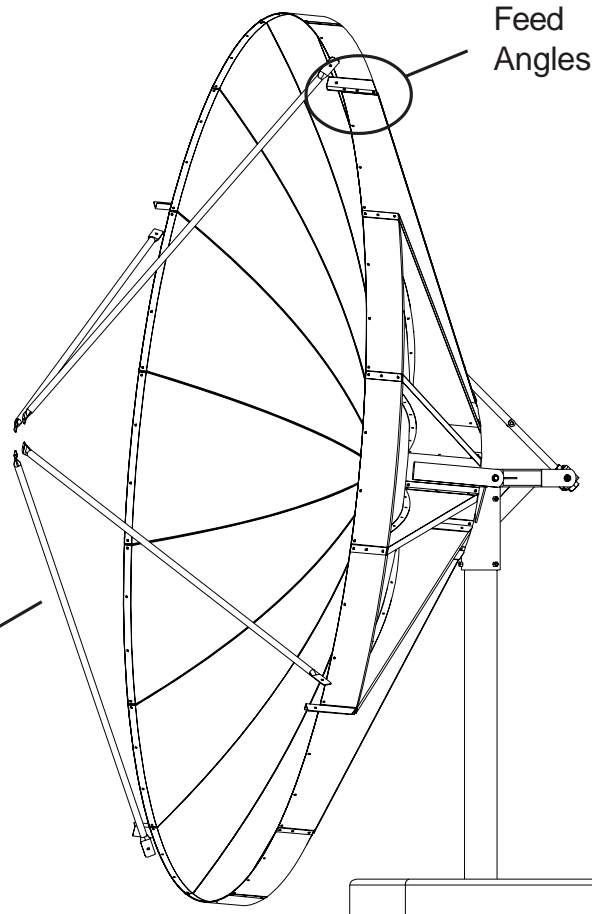

11. Assemble the Feed Plate to the inside of the Feed Struts as shown using the 1/4" hardware also from the Feed Strut Top pack. Then assemble the feed scalar to the dish side of the plate using the 4 slotted holes with the feed cover bottom half to the opposite side of the plate.

(Optional feed cover pt# COVR-STD pictured)

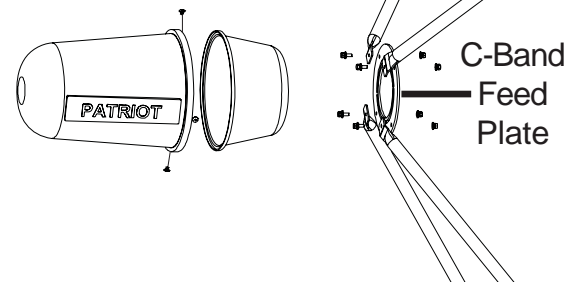

OPTIONAL
PT# COVR STD

ADL-RP1LPF200
ADL-RP1CP300
ADL-RP-3-CKU
ADL-RP3CKUIWC
ADL-KU-901
ADL-KU-850
ADL-RP2CP300

OPTIONAL
PT# COVR-SVY

ADL-RP3AZOP-122
ALL SEAVEY C-BAND FEEDS

13. With a helper place the center plate in place in the center of the opening of the petals using hardware from **Center Plate** pack. From behind place the back brace through the hub center across the hub opening. Tighten the nut on the bolt being careful not to overtighten which could crush the petals.

NOTE: If you need to climb into the dish be sure to place your feet along the Radial Beams and not into the center areas of a panel!

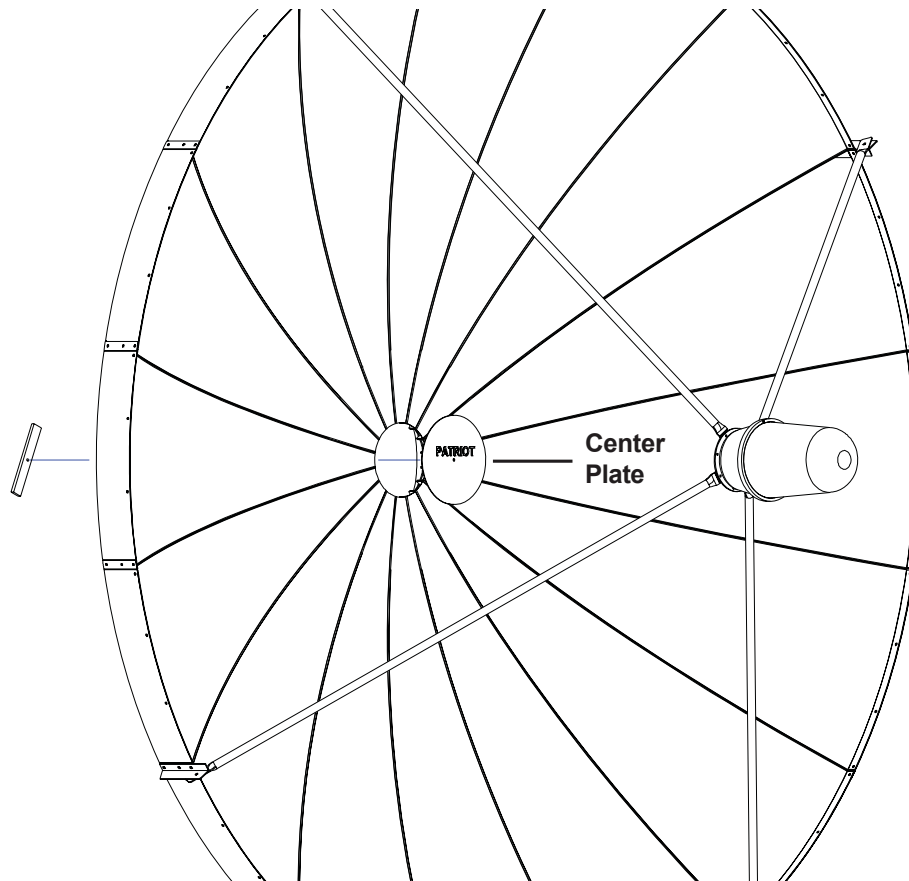

The antenna assembly is now complete. To adjust the antenna toward the selected satellite you must first know its elevation angle above horizon. This will be the reference angle for the face of the antenna. Using an inclinometer on the face of the antenna pre-adjust the desired angle using the 2 nuts of the threaded rod on each side of the lower pivot block on back of the mount. Tighten the Az-El pipe head bolts only enough to allow rotation of the mount on the ground pipe. Knowing the azimuth angle of the satellite from due south roughly aim the antenna in that direction. With the LNB connected to the proper sight-in equipment the antenna can be accurately adjusted to the satellite signal. Tighten all hardware.

Grounding

Grounding Antenna Feed Cables

1. Ground antenna feed cables in accordance with current National Electric code and local electric codes. The illustration shows a typical grounding method.

Clamps that provide a solid connection between ground wire and a ground source should be used.

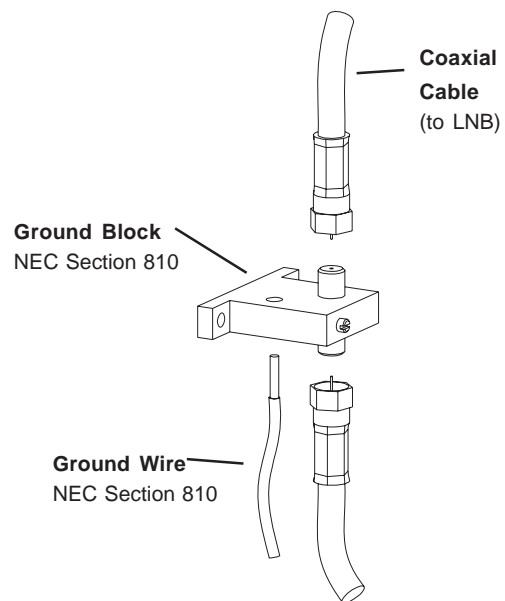

Grounding Non-Penetrating Mount Frame (if applicable)

1. Ground the Non-Penetrating mount frame. The illustration shows a typical grounding method.

Refer to the NEC Section 810 and local electric codes for specific instructions on grounding the remaining end of the ground wire.

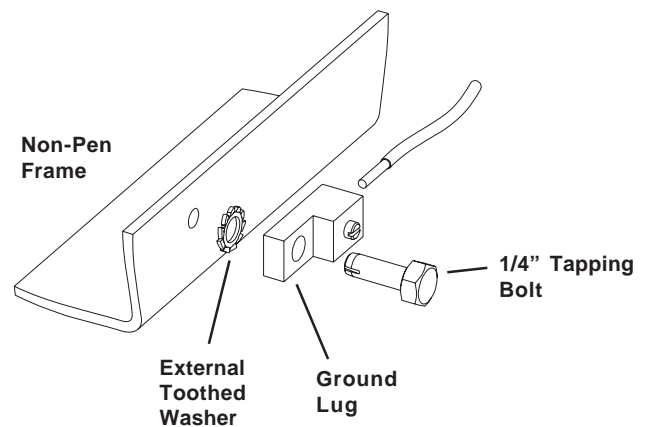

Antenna Pointing

- 1) Begin by obtaining the correct Az/EI pointing data for the satellite of interest based for your site location.
- 2) Using an inclinometer or position readout form controller placed on the enclosure drum surface, position the antenna to the specified elevation angle.
- 3) Manually scan the antenna (back-and-forth in the azimuth around the direction of the specified azimuth angle) to achieve the maximum transponder signal.
- 4) Next repeat the procedure for elevation.
- 5) Repeat this procedure alternating between the azimuth and elevation until maximum transponder signal is achieved.

Windload Information

Windload Imposed at 125 mph

Force on Front of Dish - 6,250 lbs
Force on Back of Dish- 3,400 lbs
Torque at Base of Mount- 42,000 ft.lbs.
Overturning moment- 44,000 ft.lbs.

Stress of 6" schedule 40 pipe - 49,233 psi
Stress of 6" schedule 80 pipe - 34,302 psi

Note: For Windloads of 100 mph or more, we recommend using schedule 80 pipe filled with concrete

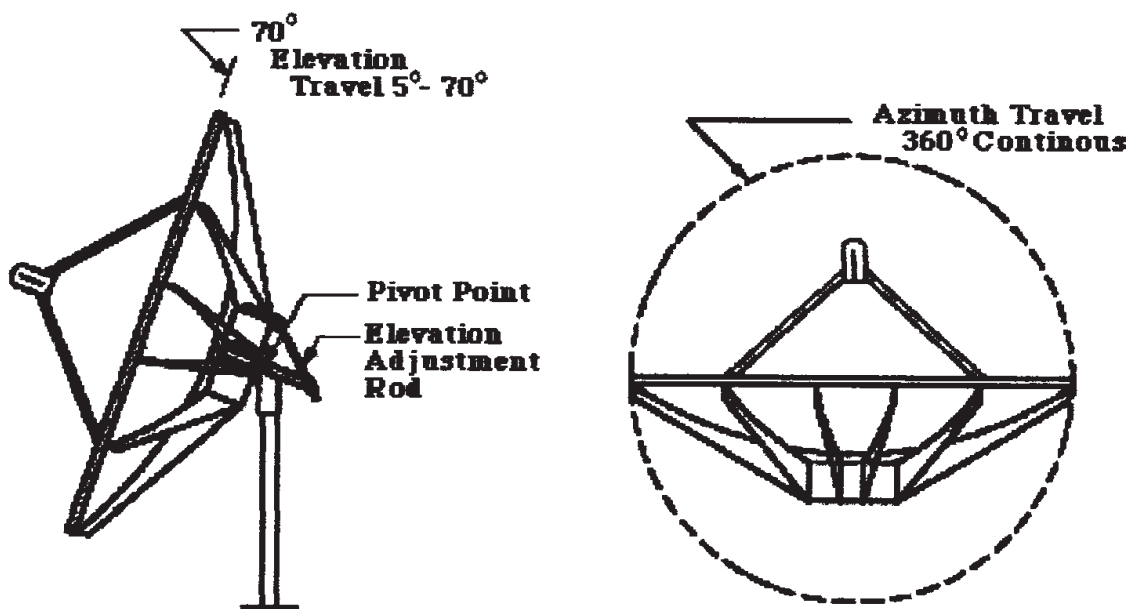

Specifications

Electrical

	C-Band	Ku-Band
Gain	41.5 dBi	50.5 dBi
Noise Temp. (20 degree elev)	30K	25K
(30 degree elev)	25K	21K
3dB Beamwidth	1.3Deg	.45Deg
Avg 1st Side Lobe	-23dB	-23dB
Cross Polarization	-35dB	-35dB
VSWR (max)	1.3:1	1.3:1
2 Degree discrimination	22.5dB	22.5dB

Mechanical

Antenna Size	3.8m (12'5")
Focal Distance	1.57m (61.95")
F/D	.413
Operational Wind	50mph
Survival Wind	125mph
Operational Temp	-40 to 140 F
Rain	Operational = 1/2in./hr Survival = 3in./hr
Ice	1 in. Radial -or- 1/2 in. + 60mph wind
Pole Size	6 5/8" OD

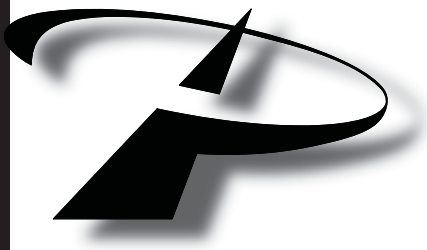
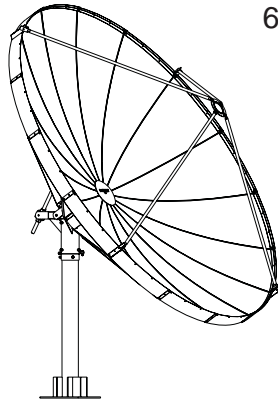

PATRIOT ANTENNA SYSTEMS
704 NORTH CLARK STREET
ALBION, MICHIGAN 49224 USA
WWW.SEPATRIOT.COM